

ENER314-RT

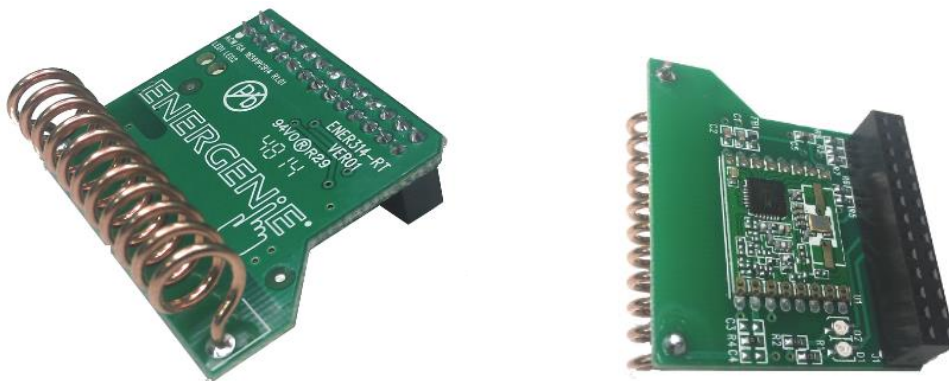

Introduction

The ENER314-RT Raspberry Pi add-on board can be used to allow the Pi to communicate with devices with 433MHz ISIM band radio. It incorporates the RFM69W radio transceiver module which can be programmed to operate with FSK, GFSK, MSK, GMSK and OOK modulation. All major RF communication parameters are programmable and most of them can be dynamically set. The ENER314-RT offers the unique advantage of programmable narrow-band and wide-band communication modes. It is also optimized for low power consumption while offering high RF output power and channelized operation.

The ENER314-RT can be used with the legacy Energenie OOK radio controlled sockets and also with the MiHome FSK controlled devices using the Openthings protocol.

Users can download the bcm libraries required and software from our website: www.energenie4u.co.uk

Installing the Board



Figure 1 (Raspberry Pi B+ with RF Transceiver Board)

The add-on board connects to the row of pins called the GPIO which can be controlled as either input or output lines under your software control. Install the board on to the row of pins as show in the picture and connect your Raspberry-Pi as normal to a monitor, mouse, keyboard and USB power supply.

Note: The RF transmitter add-on board must be connected securely first before powering on the R-Pi. Connecting after the R-Pi is on may result in the device freezing.

The pin-header connects to the add-on board as follows to allow you to control the GPIO lines as outputs to drive the radio frequency transmitter.

RFM69W				RFM69W	
	3V3	1	2	5V	
	GPIO2	3	4	5v	
	GPIO3	5	6	Ground	
	GPIO4	7	8	GPIO14	
	Ground	9	10	GPIO15	
	GPIO17	11	12	GPIO18	
LED GRN	GPIO27	13	14	Ground	GND
LED RED	GPIO22	15	16	GPIO23	
3V3	3V3	17	18	GPIO24	
MOSI	GPIO10	19	20	Ground	GND
MISO	GPIO9	21	22	GPIO25	RESET
SCK	GPIO11	23	24	GPIO8	
	Ground	25	26	GPIO7	SS

Figure 2 (GPIO pin header)

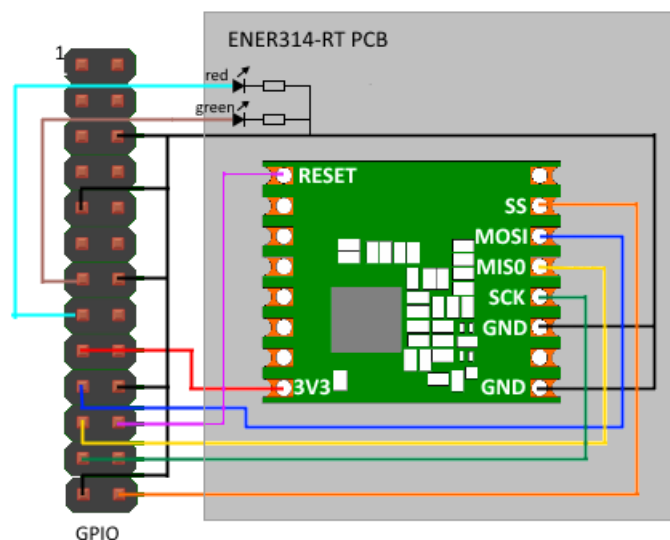

Sample Program with Energenie ENER002 radio

sockets

The board can communicate with the Energenie ENER002 radio controlled sockets using On-Off-Keying (OOK) which is a basic form of Amplitude Shift Keying (ASK). The frame of information sent has a source address (20 bits) and control data (4 bits). The sockets are receive only devices so there is no acknowledgment to the sender.

Here are the pairs of codes that can be sent to control the sockets.

D3	D2	D1	D0	Meaning	D3	D2	D1	D0	Meaning
1	0	1	1	All on	0	0	1	1	All off
1	1	1	1	socket 1 on	0	1	1	1	socket 1 off
1	1	1	0	socket 2 on	0	1	1	0	socket 2 off
1	1	0	1	socket 3 on	0	1	0	1	socket 3 off
1	1	0	0	socket 4 on	0	1	0	0	socket 4 off

The receivers within the ENER002 have 4 programmable address slots and the above codes are the combinations that can be used.

The software package on our website contains the bcm libraries vital for functioning with the GPIO pins on the Raspberry Pi. bcm 2835 is a C library for Raspberry Pi (RPI). It provides access to GPIO and other IO functions on the Broadcom BCM 2835 chip, allowing access to the GPIO pins on the 26 pin IDE plug on the RPI board so you can control and interface with various external devices. It provides functions for reading digital inputs and setting digital outputs, using SPI and I2C, and for accessing the system timers.

Setting up the sockets

The socket needs pairing with the Raspberry Pi. Hold down the green power button on the adapter housing for 6 seconds until the red LED light on the socket begins to flash at 1 second intervals. The socket has now entered learning mode. The next section describes how to initiate the program. The program has to transmit the control codes for the sockets to pair with the Raspberry Pi. The red LED lamp on the adapter will stop flashing and turn off. The adapter is has now paired with the selected button pair on the Raspberry Pi which can now be used to switch power to the socket part on or off.

Setting up the Raspberry Pi

To set up the Raspberry Pi for the first time before running the software please download the software package found on our website. Copy all the files unto the Raspberry Pi. Install bcm2835 drivers if not already installed. To do this open the LXTerminal application found on the raspberry Pi desktop. Enter the bcm2835 directory. Once in the directory type the following command: `tar zxvf bcm2835-1.37.tar.gz`. This will unzip the folder. Then type `cd bcm2835-1.37`. Then Type the following commands.

```
./configure
make
sudo make check (This command should pass the test) // test should
pass
sudo make install
```

The bcm libraries have now been installed. Now exit the bcm directory using `cd ..`. Enter into the 'HopeRF_TRX' directory. Then type the following commands:

```
make  
chmod +x hoperf_trx  
sudo ./hoperf_trx
```

This will initiate the program. Press Ctrl+C to exit the program. The sockets can now be paired with the Raspberry Pi. The first socket with Socket 1 pair and the second socket with socket 2 Pair.